

Strategies for Operations of Vertical Shaft Kilns

P. C. Okonkwo

Department Chemical Engineering.
Ahmadu Bello University
Zaria, Nigeria.

S.S Adefila

Department Chemical Engineering.
Ahmadu Bello University
Zaria, Nigeria.

Abstract

Vertical shaft kilns have among others the advantage of low investment profile and hence very suitable for small and medium scale processing of various solid minerals such as limestone. The low investment profile therefore makes it attractive in developing countries where sources of investment capital are lean. Vertical kilns however are plagued with a number of operational problems such as channeling, stratification, hanging accident, poor heat distribution among others. This work investigated the effects of burner types, firing rate and degree of draft on the vertical kiln temperature profile and hence the efficiency of the kiln. A pilot twin shaft lime kiln of 1.5 ton per day capacity was employed in the evaluation. It was shown that low firing rates of the burners affects negatively the kiln throughput and very low drafts lead to excessive backfiring of the burners. Many strategies were proposed to mitigate various negative phenomena experienced in the operations of vertical kilns.

Keywords : Vertical shaft kiln, Operation, strategy, investment, Burner, Firing, Profile.

1.0 Introduction

The vertical shaft lime kilns have been shown to possess a lot of potentials in the lime industry (Okonkwo et al 1991). In view of the need to set up more small/medium scale chemical plants to meet with the local needs of chemical products like lime, the vertical shaft kilns offers a good investment options. This is because of the following over-riding advantages shaft kilns possess over the rotary kilns.

- (a) Low initial capital investment
- (b) Low cost of operation
- (c) Good flexibility of operations
- (d) Low environmental pollution effects

Also the vertical shaft kilns because of its labour intensive nature is appropriate for developing countries where labour is cheap and unemployment rate is very high.

This work therefore seek to establish important strategies for operations of fired vertical shaft kilns in order to achieve efficient operations which will ultimately encourage investments in vertical shaft kiln facilities. This is hoped will create multiplier effects that will catalyze growth of developing economies.

A good and efficient kiln should possess the following features (Predescu 1989);

(a) Temperature Uniformity

The vertical shaft kiln comprise of zones which are characterized with definite range of temperatures. The zones are from the top of the kiln ; preheating zone, burning zone , finishing zone and the cooling zone. The material in the kiln are exposed to the temperature ranges in the zones order to effect adequate processing of the materials. The uniformity of the temperature in the zones will ensure that the material is adequately processed and that energy consumption in the system is minimized

(b) Repeatability

Repeatability is a characteristic desired by kiln operator. A good kiln should achieve the same level of productivity through all cycles. This will assure consistent quality of products.

(c) Reliability

A good kiln should be reliable. This characteristic ensures that the operator obtains design specifications and limits from the kiln and that the productivity of the kiln is high.

(d) Flexibility

A good kiln should also possess a good deal of flexibility. The operator should have a good latitude to respond to varying market demands and meet varying quality and throughput levels.

(e) Economy

A good kiln must be economical. True economy depends not only on a kiln's cost but its return on investment. A good kiln will not be unduly expensive and should be also economical to operate.

(f) Safety

The kiln should be safe to operate both to ensure the safety of the operator and the equipment.

(g) Simplicity

The kiln should be simple and straight forward. The operations should also be easy.

The heart of a lime plant is the kiln. The prevalent type of kiln is the rotary kiln which accounts to about 90 percent of all lime production in the world (Ellis 1960). The kiln is a long, cylindrical, slightly inclined, refractory-lined furnace, through which the limestone and hot combustion gases pass counter currently. Coal, oil, and natural gas may all be fired in rotary kilns. Product coolers and kiln feed preheaters of various types are commonly used to recover heat from the hot lime product and hot exhaust gases. The next common type of kiln is the vertical shaft kiln. This kiln can be described as an upright heavy steel cylinder lined with refractory material. The limestone is charged at the top and is calcined as it descends slowly to discharge at the bottom of the kiln. A primary advantage of vertical kilns over rotary kilns is the higher fuel efficiency. The primary disadvantages of vertical kilns are their relatively low production rates and the fact that coal cannot be used without degrading the quality of the lime produced.

Other much less common kiln types include rotary hearth and fluidized bed kilns. Both types can achieve high production rates but neither can operate with coal.. The calcimatic kiln or rotary hearth kiln is a circular kiln with a slowly revolving doughnut-shaped hearth. In fluidized bed kilns finely divided limestone is brought into contact with hot combustion air in a turbulent zone usually above a perforated grate. An emerging process is the parallel flow regenerative(PR) lime kiln (Parson 1988). This process combines two advantages. First , optimum heating conditions for lime calcining are achieved by cocurrent flow of the charge material and combustion gases. Second, the multiple chamber regenerative process uses the charge material as the heat transfer medium to preheat the combustion air. The basic PR system has two shafts, but three shaft systems are used with small size grains to address the increased flow resistance associated with smaller feed sizes.

The major problem with traditional shaft kiln is obtaining uniform heat release and movement of the burden across the shaft. Fuel injected at a wall usually does not penetrate more than 1m into a packed bed. This limits the kiln productivity. Figure 1 shows a schematic diagram of a shaft kiln. The challenge of operating a shaft kiln to obtain high productivity is dependent on efficient control strategies There are three important features which are common to the various designs of shaft kilns. Single point charging of lump raw material especially to shaft kilns can lead to problems in kiln operation.

1.1 Factors that affect Operations of Vertical Shaft Kilns

The following factors affect the operation of fired kilns:

1.1.1 Heat Flow Pattern

The heat flow pattern usually follow the draft design. There are three basic design options for kiln draft: (a) updraft kiln (b) downdraft kiln and (c) modified downdraft kiln.

(a) Updraft kiln

An updraft kiln has burners located at the base. The flue exit is located at the top of the kiln. The flame and heat travel in one direction. The flame enters at the bottom and exits at the top.

(b) Downdraft Kiln:

The kiln. The flame enters at the bottom is deflected to the top of the kiln and is then pulled back down and out the flue. In the downdraft the flame and the heat stay In the kiln for a longer tim and more of the heat can be liberated before it exits from the kiln.

(c) Modified Downdraft kiln

The modified downdraft system requires high-velocity burner mounted on the top of the kiln. The flame from the high velocity burner is shot down the kiln completely recirculation in the kiln and exits out the flue at the kiln top. This provides for exceptionally even heating and energy recovery. The modern regenerative kilns operate on this principle.

1.1.2 Burners. Type

There are basically two types of burners:-

- (a) Inspirator type, which relies on the fuel gas pressure to entrain and mix the air as it emerges from the orifice.
- (b) Aspirator type, which relies on a blower or forced -air system to entrain the fuel gas.
- (c) Premix burner, which uses either an inspirator or aspirator mixer to mix the fuel gas and air at some point upstream from the burner ports. The burners capacity must match the kiln's heat requirement.

1.1.3 Fuel

Kilns employ variety of fuels namely:- Wood, Oil, Natural Gas, Liquefied Petroleum Gas. The type of fuel to be used will depend on the economics and local legal requirements.

1.1.4 Safety Systems

The three systems generally used are Baso, flame rod, and Ultraviolet scanner (Valec 1990). A Baso system generally includes Baso valve, thermocouple and pilot burner, and no electricity is required to operate the system. Flame rod and Ultraviolet Scanner flame detectors are the most often used, these provide 100 percent shut-off incase of flame or power failure and they are not limited to lower capacity burners.

2. 0 Materials and Methods.

A 1.5 ton per day Twin Vertical shaft kiln was deigned and constructed. The kinetics of calcination and the kinetic parameters of Jakura limestone was used as the basis of the design. The kiln was fired with pressurized kerosene as fuel. The details of the kiln have been described (Okonkwo 2000) . In this two shaft system , the shafts alternate functions, with 1 shaft serving as the calcining shaft and the other as the preheating shaft. Limestone is charged alternatively to the 2 shafts and flows downward by gravity flow. The 2 shafts are connected near the base to allow gas flow between them. One shaft functions as the calcining shaft and the other as the preheating shaft during a firing cycle. In the calcining shaft combustion gas(air/fuel mixture) is fired downward through the limestone charge material. The hot combustion gases pass from the combustion zone in the calcining shaft and exit through the connecting channel into the preheating shaft where the hot gases exchange heat further with the limestone charge in the preheating shaft hence preheating the charge. The function of the two shafts reverses on a 4 hour cycle and each shaft is furnished with twin burners. The temperature profile of the kiln was monitored from four positions along the kiln shaft from the top of the kiln located at 0.17m, 0.47m, 0.77m and 1.07m designated as positions 1,2,3 and 4 respectively. The shaft undergoing the burning cycle(calcining shaft) is the one usually monitored. The positions are connected with a thermocouple to a multichannel digital temperature readout panel. The scheme of the kiln is shown in Figure 1

3.0 DISCUSSION

3.1 Effect of Burner Type

There are basically two types of burners namely ; the inspirator type and the aspirator type. The inspirator type relies on the fuel pressure to entrain and mix the air as it emerges from the orifice. The aspirator type relies on a blower or forced air system to entrain the fuel. The premix burner uses either an inspirator or aspirator mixer to mix the gas and air at some point upstream from the burner ports. Burners stability affects the firing rate. The inspirator burner is generally more stable than the aspirator burner because the control of the inspirator burner is simpler and the pressure of the fuel is the limiting factor whereas the aspirator burner proves more difficult because the control of the flow of fuel and that of the air are often controlled independently and loss in pressure of fuel often lead to extinguishing of the flame. Figure 3 shows the firing with aspirator burner and when compared with that of inspirator premix burner in Figure 4 shows lower firing since the temperature profile across the zone over a period shows lower kiln temperatures.

As shown in Figure 3 when the kiln was fired with one aspirator burner, the kiln attained a temperature of 300°C at position 1 which is nearest to the firing front after 100 minutes of firing while when the kiln was fired with one inspirator burner the kiln attained a temperature of 600°C after 100minutes of firing as shown Figure 4.

3.2 Effect of Firing Rate

Burning of limestone in the kiln is a highly endothermic reaction and requires large input of heat for the calcinations(Moffat and Walmsely 2006) . Limestone starts dissociation reaction at 900°C (Dennis 1985) and temperatures above the dissociation temperature need to be maintained in the kiln. The burner need therefore to be appropriately sized to provide this energy requirement. The experimental kiln when fired with a single burner as against double burners showed lower temperature levels in the kiln as shown in Figure 4 and Figure 5. When the kiln was fired with a single burner position 1 which is nearest to the firing front attained a temperature of 715°C after 60 minutes firing and reached 780°C after 120 minutes firing, while when the kiln was fired with two burners the kiln attained a temperature of 900°C after 60minutes firing and reached 1070°C after 120 minutes of firing. Thus the appropriate firing rate is desirable to achieve the required calcinations temperatures in the kiln.

3.3 Effect of Draft System

The main purpose of the draft system is to expel combustion gases and CO₂ generated on calcinations from the kiln shaft. The draft system of the experimental kiln consist of blower, compressor, control valve, gauges , chimney and dampers. The blower is the main draft drive while the compressor serves as auxiliary draft drive. During operation the draft from the kiln was less when the ejector was shut down. This situation also occurred when the damper on the draft blower was opened. Low draft of the kiln lead to excessive accumulation of CO₂ in the kiln and this can cause backfiring of burners and vitiation of lime quality because of possible re carbonation of burnt lime(Hills 168) and (Baker 1962) whereas excessive draft can lead burner flame blowout .

3.4 STRATEGIES

To obtain the desired performance of kilns or to run kilns efficiently in order to assure good quality products and safety of personnel and equipment, the following operations strategies need to be employed.

3.4.1 Temperature Uniformity

A fuel-fired kiln depends mainly though not entirely on convection as the source of heat. A fuel-fired kiln with properly placed burners and flues, equipped with efficient burners can fire very much faster cycles, and ensure uniformity of temperature. The advantage of faster cycles is that a smaller kiln can be used to achieve high capacities and throughputs .

Repeatability

Once the burner air and fuel supply are under control through the use of proper controls the kiln will perform repeatability. The controls should be simple but sophisticated enough to actually do the job. The temperature programmer is an important tool that actually sets the repeatable time-temperature profile. Also the easiest way to achieve simplicity of operation is with automatic control equipment that will reproduce a given cycle without attention.

3.4.2 Instruments and Controls

The instrumentation system may consist of air and gas pressure indicators as well as temperature indicators, controllers and programmers. The air and gas meters monitor the burners to see that they are properly in balance (usually good equipment is easy to balance and does not drift, so resetting is rarely necessary). The temperature indicator shows whether the kiln is at the right temperature at the right time,.

The combustion system works by connecting the air line to the top of the zero regulator. However for a separate zone of control when burners are in levels (upper and lower) then both the gas and air piping for each zone must be installed separately. When one blower is employed, the air lines must be divided so that a control valve in the air line is only controlling the air for the zone of interest . It is also possible to mount a control motor in the piping right on the zone control valves. Sometimes it is important to know what the temperature in the kiln is. Controllers can be employed, which will show both the set point of the controller and the temperature received by the thermocouple. For a permanent record of entire firing a recording instrument can be used and will give a printed record of the temperature in each zone throughout the firing.

3.4.3 Channelling and Hanging Accident.

Most of the defects of the vertical kiln namely' irregularity of operation, overburning, deterioration of refractories etc are caused by channeling. Channeling is the tendency of some parts of the kiln shaft to run at higher temperature than others. This is a combustion phenomenon that results from the combination of. fuel and air in the voids in the kiln charge[1] (Okonkwo,1991). Since channeling is caused by the mixing of the fuel and air in the kiln, if we combine the air and fuel outside the kiln and fire with complete products of combustion the coolest portion of the charge will draw the highest volume of gases and will soon equalize in temperature. We would then have a dynamically stable condition and channeling would be eliminated [4] (Parsons 1998). Without channeling it should be possible to realize the advantages of burning smaller stones in vertical kilns without the incidence of over burning which can lead to fusing of some sections of kiln feed thus resulting In hanging and blocking of the kiln passage, especially in vertical shafts.

4.0 Conclusion

Successful operation of kilns depends on many factors. In this work the effects of burner types , firing rate and kiln draft have on the temperature profile of vertical kilns have been shown and strategies for realizing efficient operations of vertical shaft fired kilns have been proposed. These strategies will enable operators of this equipment to achieve the desired features of an efficient. kiln that meet the design specifications. Investors with small capital base can employ the proposed strategies to run efficient vertical kilns.

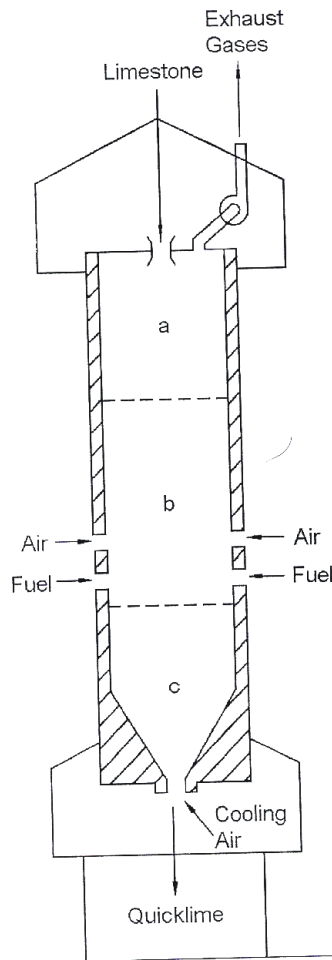

FIGURE 1: Cross- section of normal vertical shaft kiln. (a) the preheating zone, (b) calcining zone; (c) the cooling zone (Agnieszka 2005)

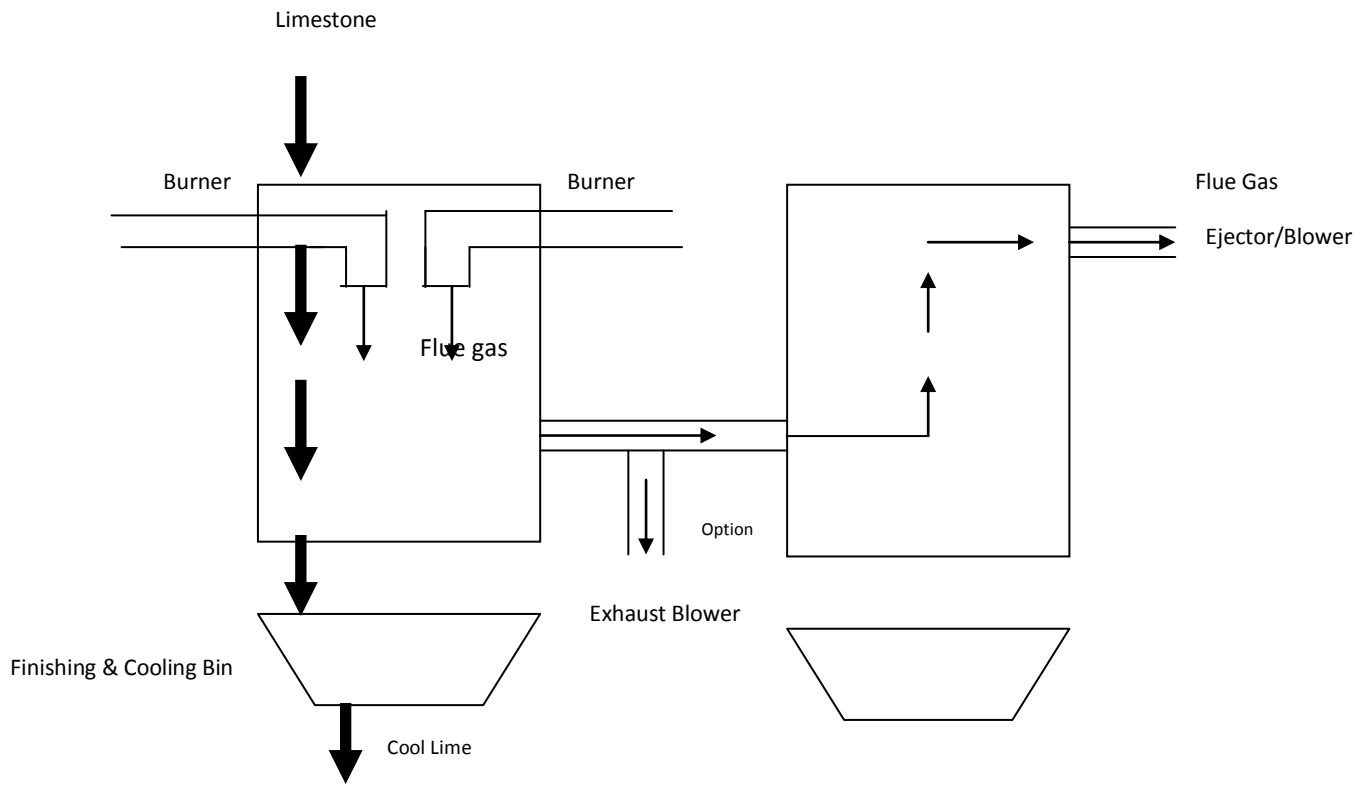

FIGURE 2 FLOW SCHEME OF THE TWIN SHAFT KILN FOR

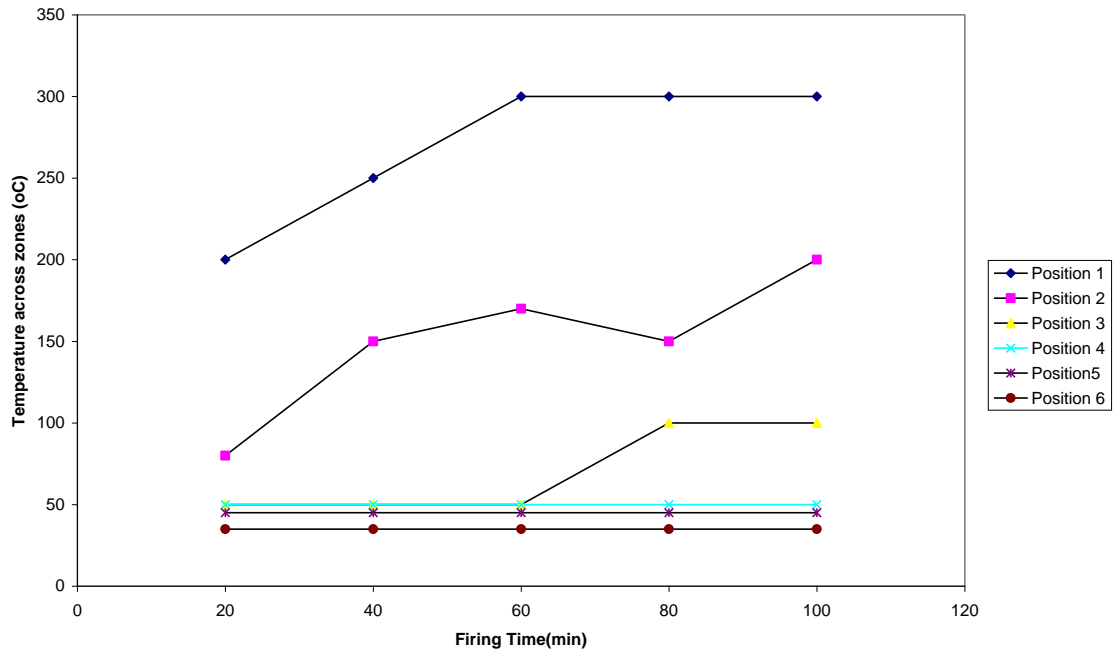

Figure 3 Temperature Profile of Kiln fired by Single Aspirating Burner

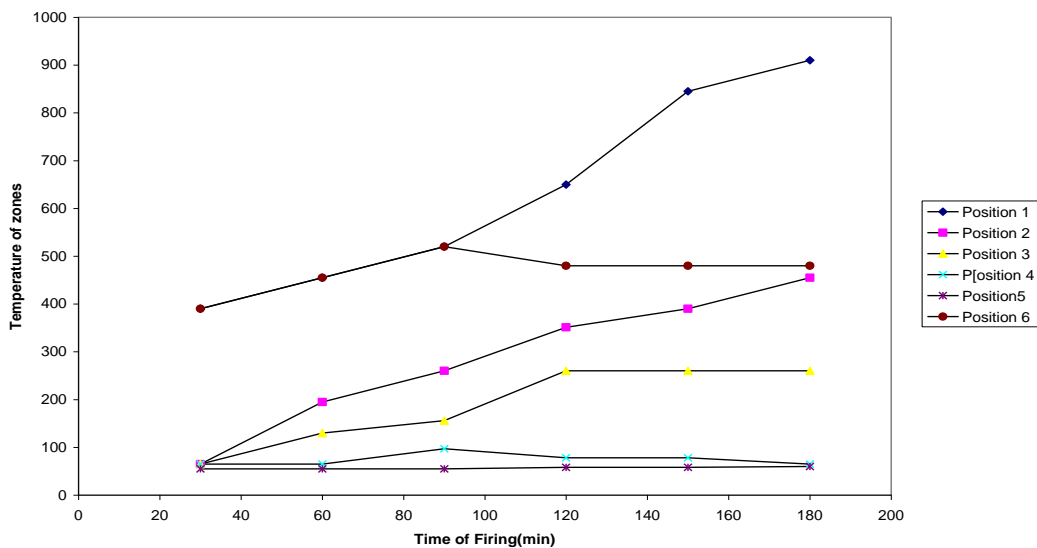

Figure 4 Temperature Profile of kiln fired with Single Premix Burner

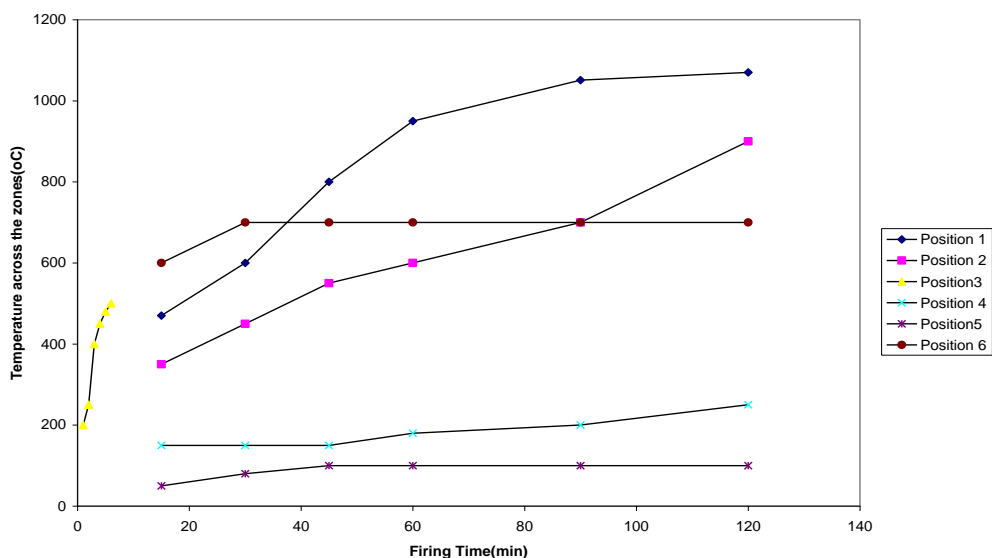

Figure 5 Temperature Profile of kiln fired with 2 Premix Burners

References

- Okonkwo P.C, Adefila S.S, Beecroft G.A Approach to Design of Vertical Shaft Kiln Proceedings of Nigerian Society of Chemical Engineers Conference 1991
- Predescu I. (1989) Pleading for the Vertical Lime Kiln” La Technique Moderne (April 1989)
- Ellis C.(1960) Various Methods of Improving the Efficiency of Rotary Lime Kilns” National Lime Association Operating Meeting (Sept 29 1960).
- Parson’s M.E. (1988) A New Approach tot eh Vertical Shaft Kiln”. Pit and Quarry (Jan. 1988)
- Agnieska B(2005) PhD Dissertation Otton –von- Guericke- Universitat Magdeburg.
- Okonkwo P.C (2000) PhD Dissertation Ahmadu Bello University Zaria 2000
- Moffat W. and Walmsely (2006) Understanding Lime Calcination Kinetics For Energy Cost Reduction” 59th Appita Conference Auckland New Zealand
- Dennis J.S PhD Dissertation University of Cambridge 1985
- Hills A.W.D (1968) Chemical Engineering Science Vol.23 pp. 297
- Baker , E.H (1962) . Journal of Chemical Society 464
- Valec Unpublished Designing Lime Kiln Plant Manual 1990